



HDS TRADING CORP.

New Jersey Office

1305 Jersey Avenue

North Brunswick, NJ 08902

tel 732.418.0418 | fax 732.418.0414

# Assembly Instruction

## 5-TIER WIRE SHELVING

1. Please read the assembly instructions carefully before assembling and check all the parts.
2. Please check the parts quantity
3. Do not touch the cut surface of tube

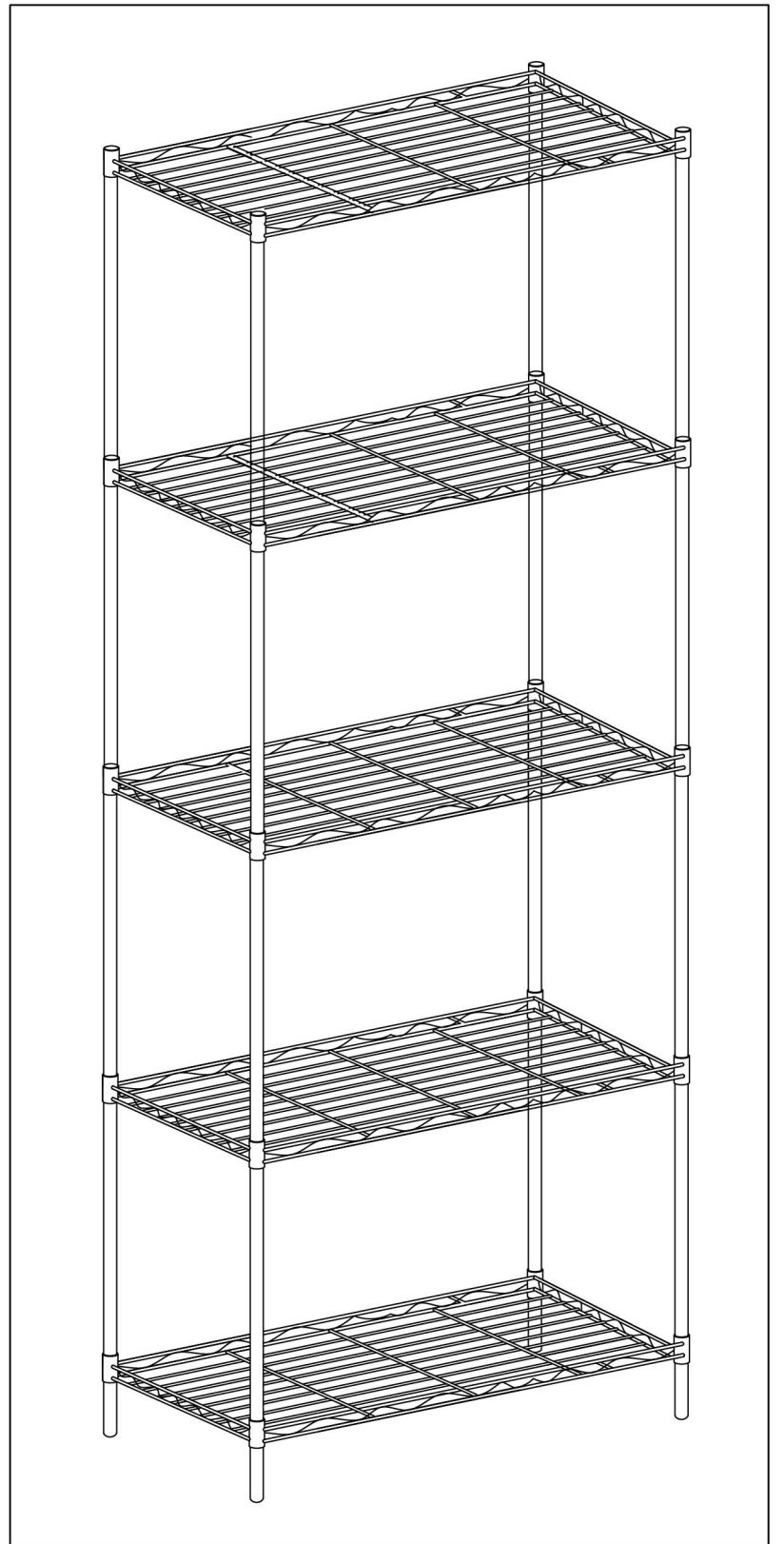

## Parts Identification

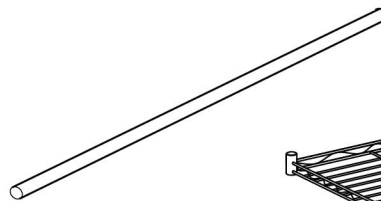
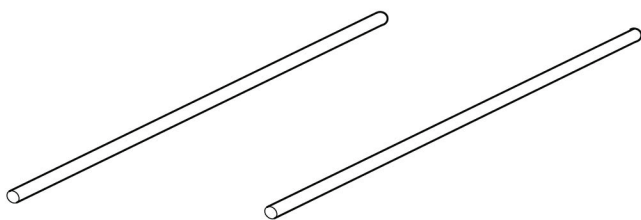

**A**

**B**

**C**

**D**

**E**

4PCS

8PCS

4PCS

5PCS

40PCS

Step 1

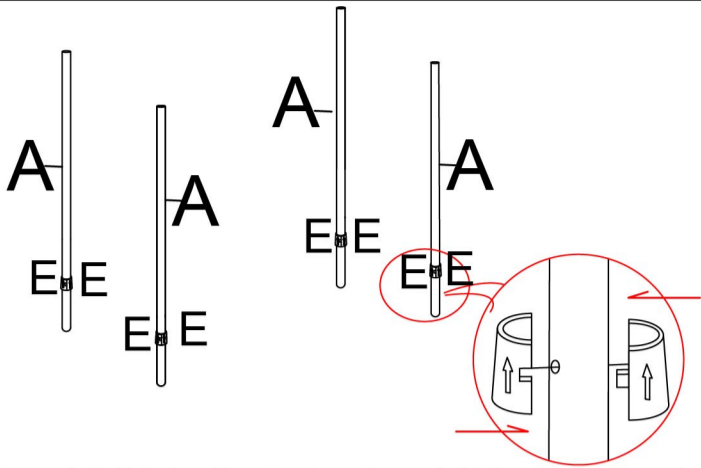

Put part (E) into the hole of part (A), please noted the gap of part (E) must be up.

Step 2

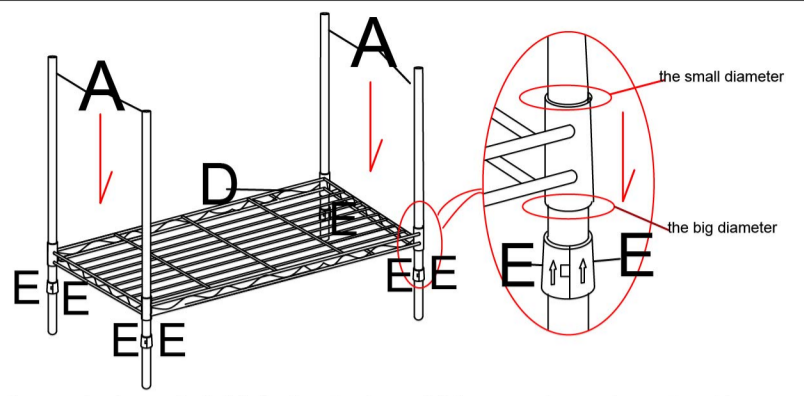

Put metal net (D) into tube (A), and arrive to the position of part (E), and note the diameter size of metal net (D).

Step 3

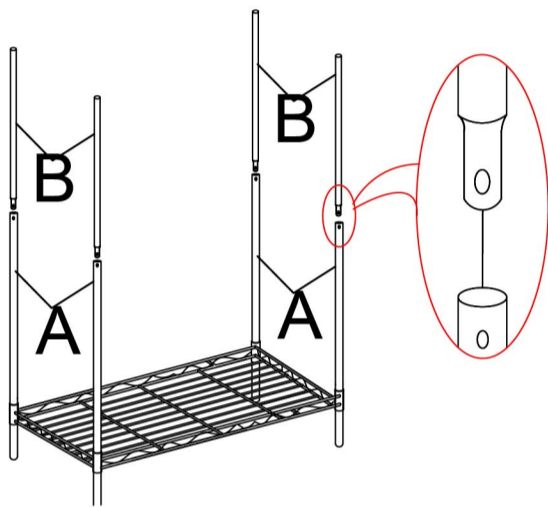

Insert tube (B) into tube (A), aim at the hole.

Step 4

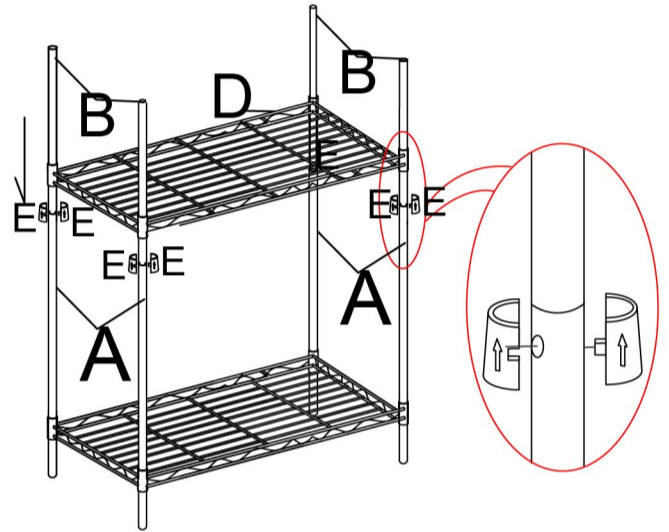

Fasten part (E) into the hole of part (B), then put the metal net (D) into tube (B).

Step 5

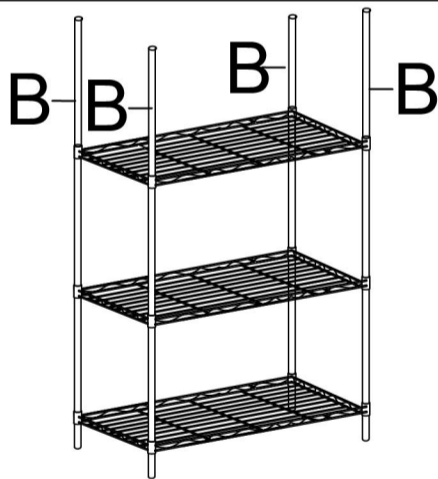

Based on step 4, repeat step 3 and step 4 one times.

Step 6

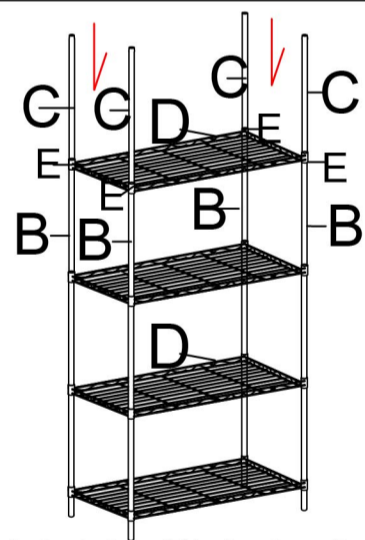

Insert tube (C) into tube (B), fasten the hole of part (B&C) with part(E), then put metal net(D) into tube(C).

Step 7

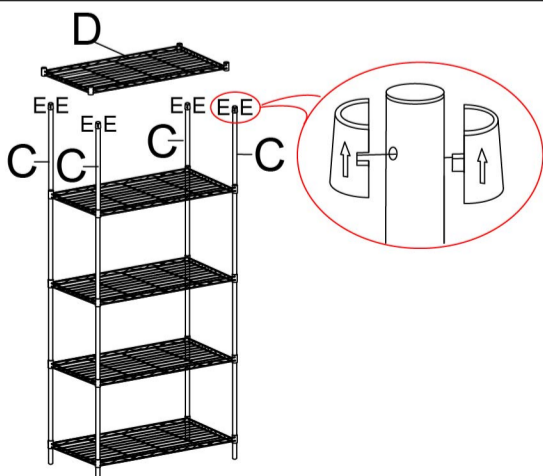

Insert part (E) into the top hole of tube (C), then put metal net (D) into tube (C).

Step 8

